



Proizvodnja dizela goriva iz električne energije vjetroenergana i fotovoltaika

Winddiesel-Diesel aus Wind und PV-Strom erzeugen (PtL)



DI Dr. Richard Zweiler

Winddiesel – das burgenländische Projekt

12.HRVATSKIH DANA BIOMASE, Našice, 8. Sept. 2017

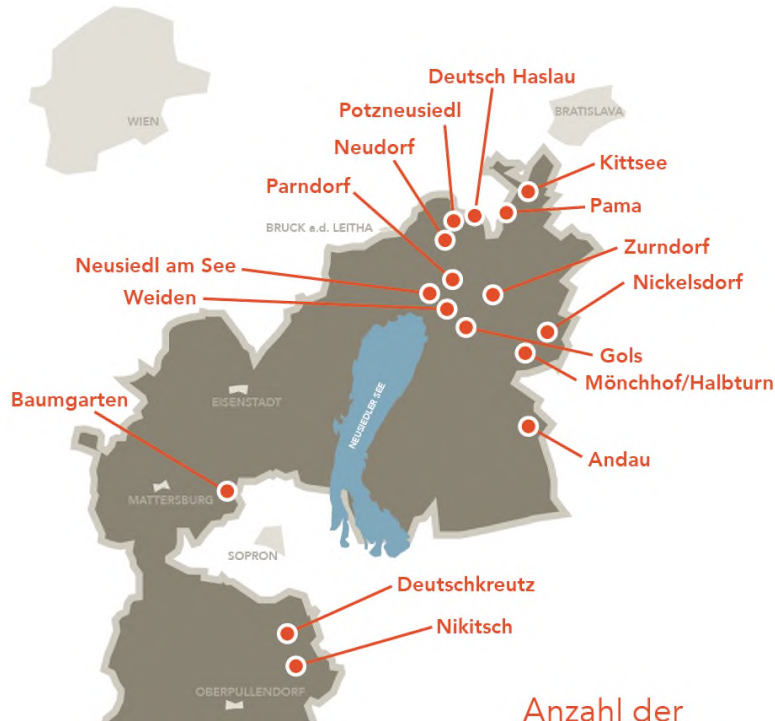

Juni 2016:
507 MW installierte Leistung
16 Windparks
 Bei den ersten Windparks
 laufen bereits in den nächsten
 Jahren die Einspeisetarife aus.

Anzahl der

6 Mon. Planung, 6 Mon. Bau, 6 Mon. IBS + Optimierung
Erstes funktionierendes Biomasse Vergasungskraftwerk der Welt. Repliziert in Villach, Oberwart, Ulm, Göteborg, etc.





Winddiesel =



Windstrom



+ Fischer Tropsch +



DFB

Prinzip DFB + Fischer Tropsch = Premium Diesel

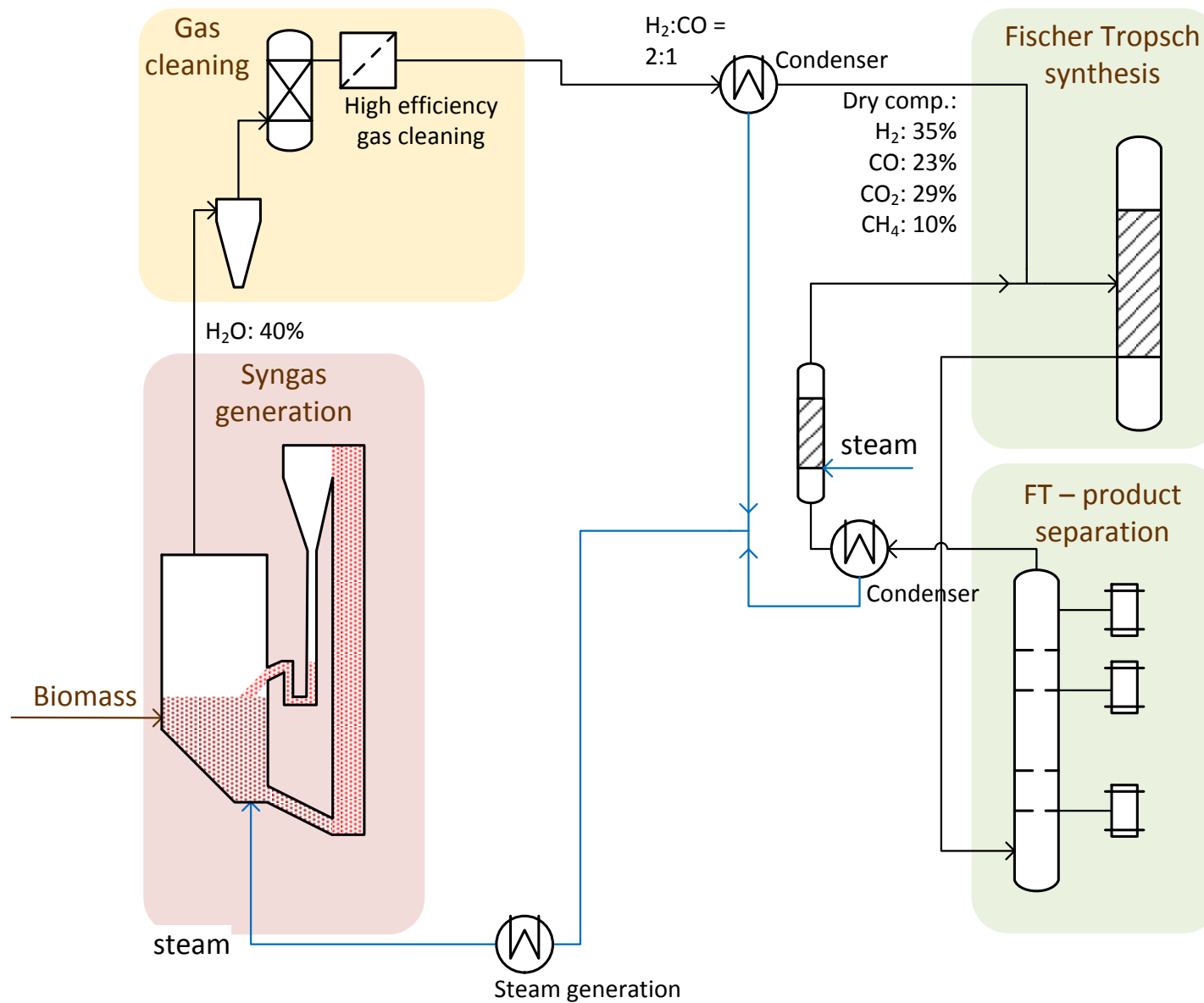

CO₂ Vergasung

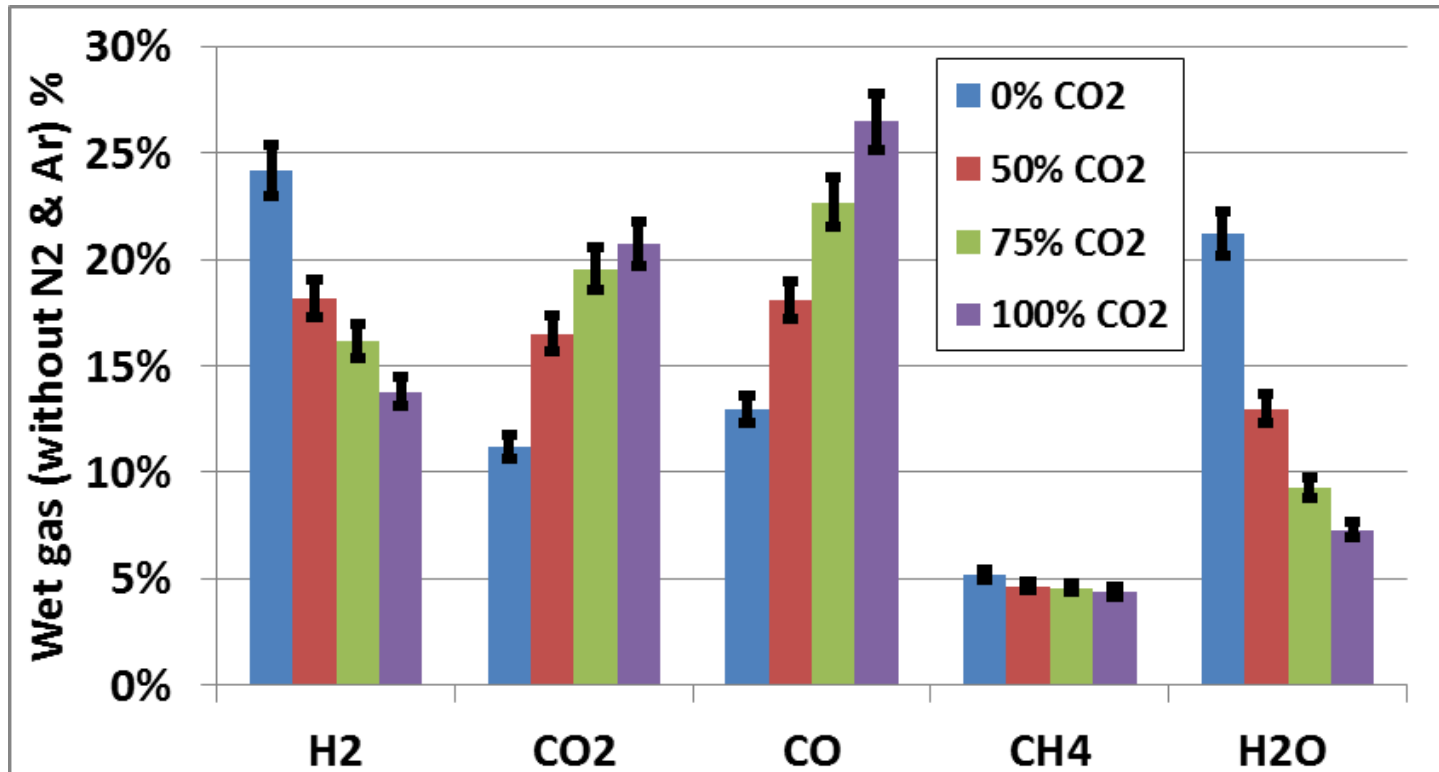

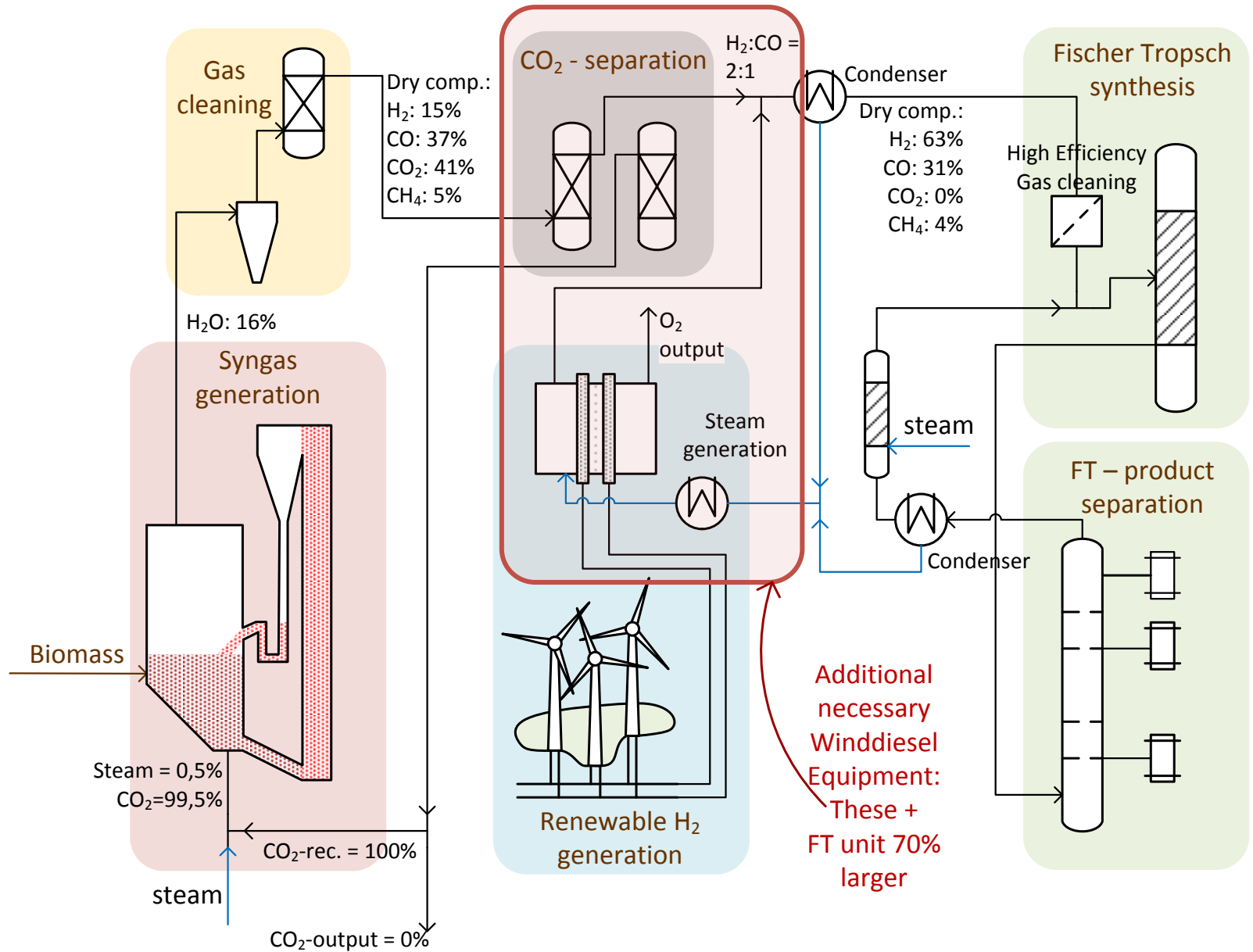

Produktion bei Basis-, Teil- & Volllast

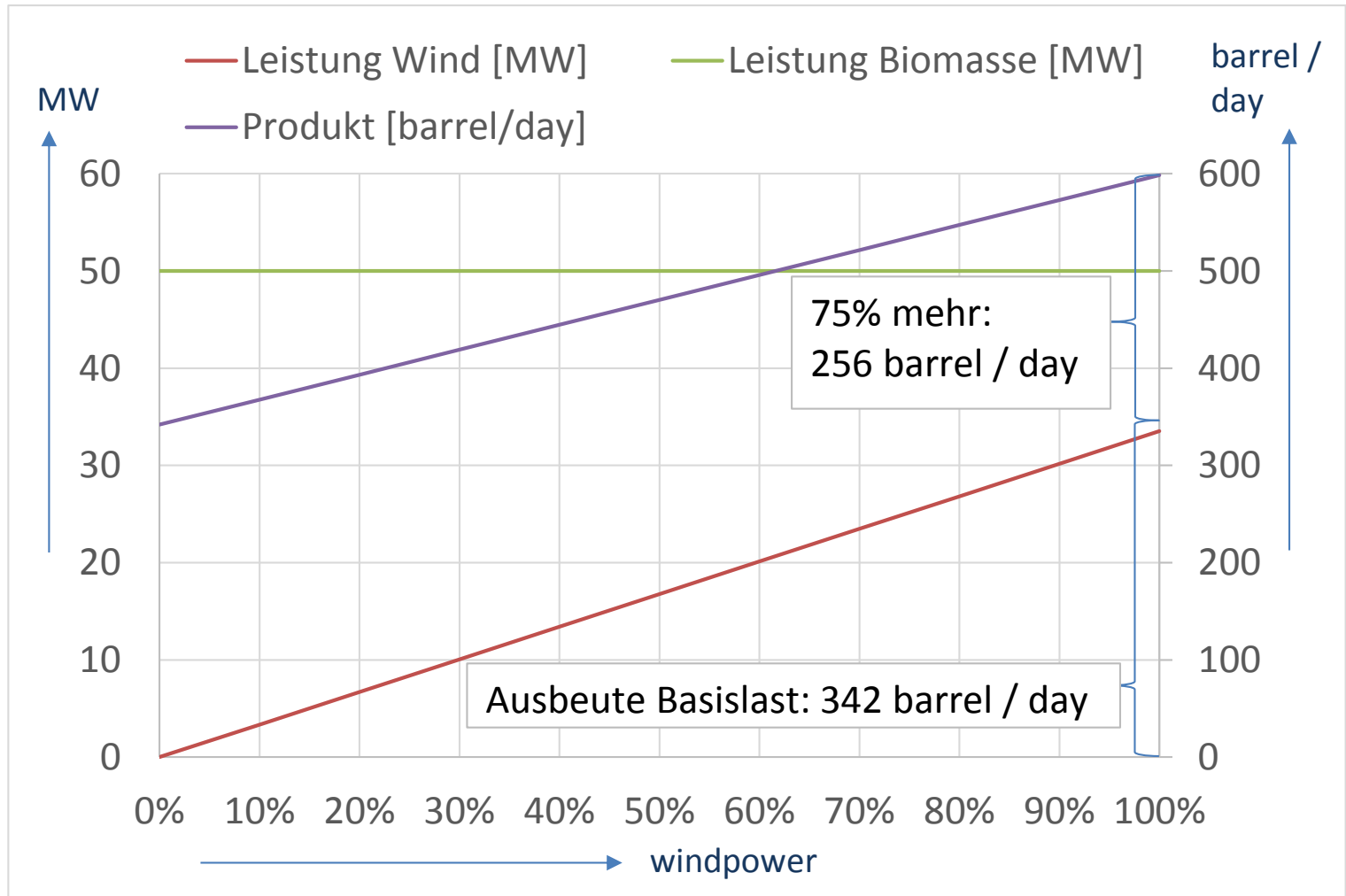

Vergleich Winddiesel – fossiler Diesel



Winddiesel:

Erzeugt aus Holz & Wind



Erzeugt aus
sämtlichen
kohlenstoff-
hältigen Abfällen
der letzten 200
Mio. Jahre

© Pictures:
Energie Burgenland:
Faszination Windkraft

© Pictures:
Top: Deepwater Horizon – USA, Gulf of Mexico – Oil Spill 2010
Petty Officer 2nd Class Justin Stumberg US-Navy ID: 100506-N-6070S-819
Bottom: Louisiana GOHSEP (Flickr: Oiled Pelicans)

Investitionskosten 50 MW Anlage:

- ◆ Premium Diesel: € 104 Mio
- ◆ Winddiesel: € 150 Mio.

Berechnungsbasis konservativ:

- ◆ Kosten Spitzenstrom 25 EUR/MWh
(Erlöse für negative Regelenergie liegen derzeit bei ca. 50 EUR / MWh)
- ◆ Erlös Diesel: 0,74 EUR/l (**0,888** inkl. MWSt.)
- ◆ 7500 Volllaststunden FT-Teil

Ergebnis: Eine Winddieselanlage kann bereits unter den aktuellen wirtschaftlichen Rahmenbedingungen errichtet werden.

Details:

- ◆ Als Demonstrationsanlage empfiehlt sich die Installation einer 50 MW Anlage
- ◆ Ab 3460 Volllaststunden Wind ist das Winddiesel Verfahren wirtschaftlicher, als eine konventionelle Premium-Diesel Anlage
- ◆ Ab 62 EUR/MWh Einspeisetarif Strom lohnt sich die Investition in einen Dampfprozess

◆ Auswirkungen FT-Wachspreis

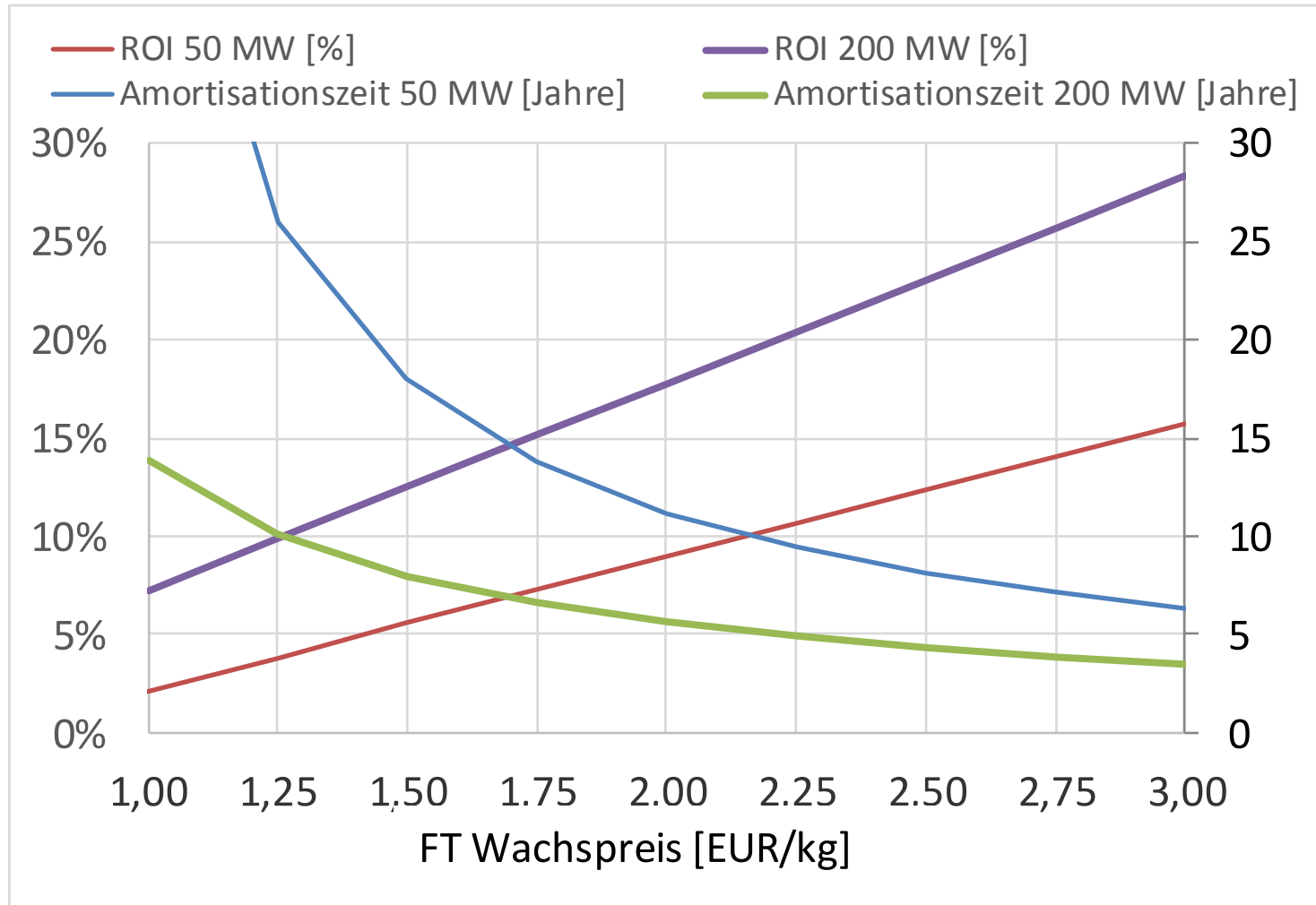

◆ Auswirkungen Strompreis

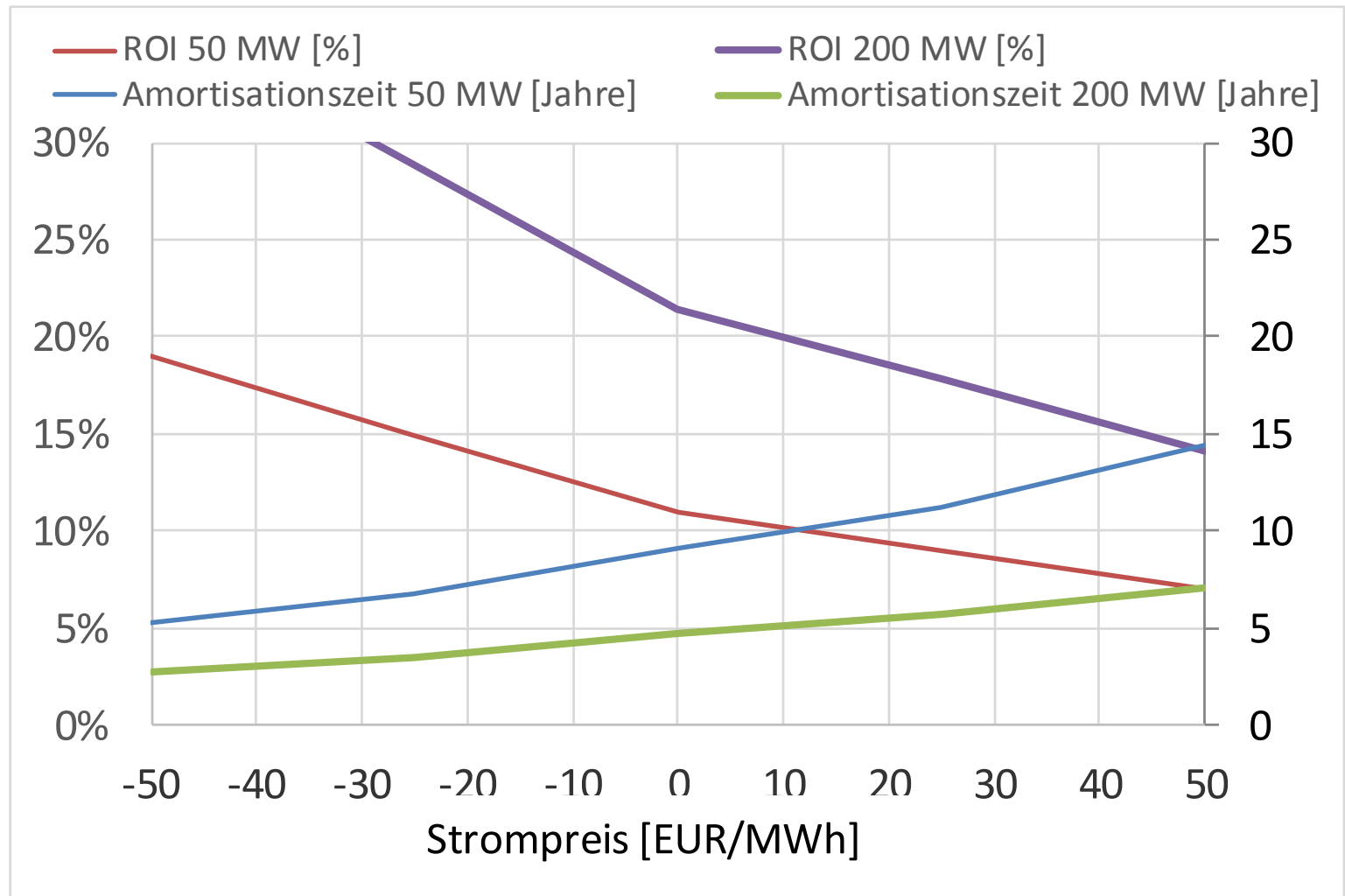



Details:

<http://winddiesel.at>

<http://winddiesel.co.uk>

<http://winddiesel.ch>

<http://winddiesel.de>

<http://winddiesel.eu>

<http://winddiesel.mobi>

<http://winddiesel.name>

<http://winddiesel.us>